

The SG 45 in a nutshell

- Compact design, only 22,5 mm wide
- Plug-in screw terminals or spring-clamp connectors
- Dual-line LCD: Process values always in view
- Simple and convenient 3-key operation
- High-resolution (23 bits) universal input for measuring bridges
- Short 50 ms cycle time
- Additional functions
 - o Tare
 - o Zero setting
 - o Integrator
 - o Convenient switching of the 80% calibrating resistor
- Simple sensor calibration during commissioning
- 4 or 6-wire connection with force sensors (sense measurement)
- Up to 4 load cells with 350 Ω each
- Application-specific linearization possible
- Min/max indicator (slave pointer)
- High-resolution, combined current/voltage output
- 2 relay outputs
- BluePort® interface for the Engineering Tool
- RS 485 / Modbus RTU protocol
- Field bus connected via bus coupler

rail line

Application solutions:

Stand alone



System solutions

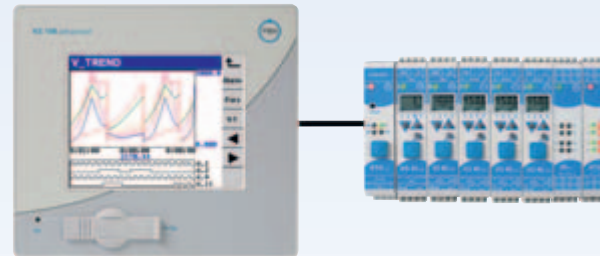

PMA Prozeß- und Maschinen-Automation GmbH
Miramstraße 87
34123 Kassel/Germany
Tel./Fax: +49 (0) 561 505-1307 / -1710
E-mail: mailbox@pma-online.de
www.pma-online.de

rail line

UNIFLEX SG 45

Special transmitter for strain gauge input



“Specialist” newly defined!

Wir kriegen's geregelt
Close the loop with PMA



Compact

UNIFLEX SG 45



- Special transmitter for strain gauge input (load cells and melt pressure sensors)
- On-site operation
- Process value always in view
- Individual units
- Maintenance manager

Special

- Simple Engineering with BlueControl®
- Parameter adjustment
- Trend recording
- Testing with simulation

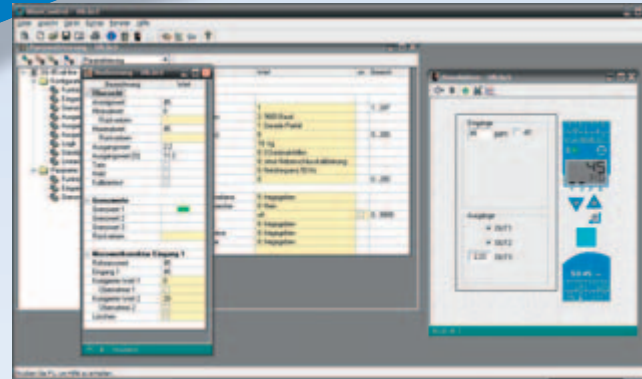

- Strain gauge sensor input
- On-board bridge energization (10 VDC)
- Calibration function (80%)

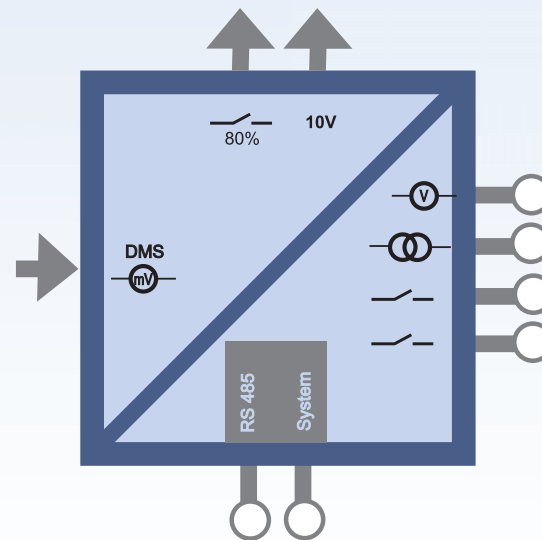

Flexible

- Plug-in screw terminals or spring-clamp connectors

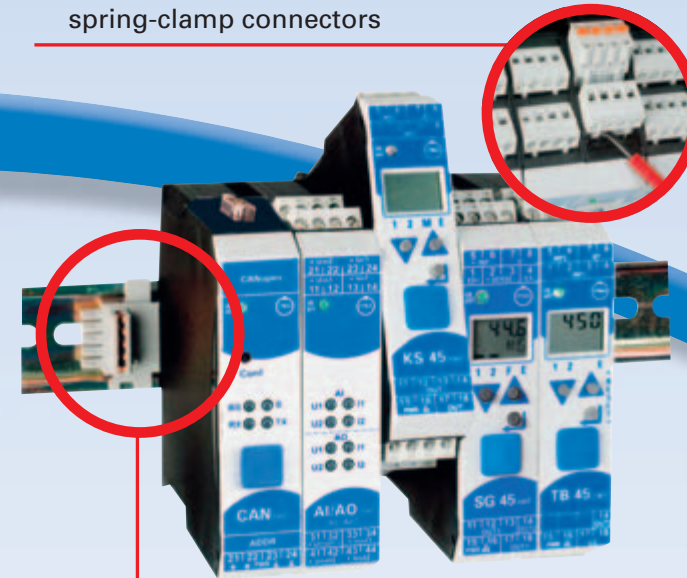

- Inter-module links for RS 485 / Modbus RTU protocol
- Close-packed mounting
- Communication via field bus coupler
- Hot swappable
- Simple, clip-on rail mounting

rail line